

ferroli

RMC

AIR COOLED WATER HEAT PUMPS
AND COOLERS WITH CENTRIFUGAL FANS

18.7 ÷ 49.7 kW IN COOLING MODE

20.4 ÷ 51.3 kW IN HEATING MODE

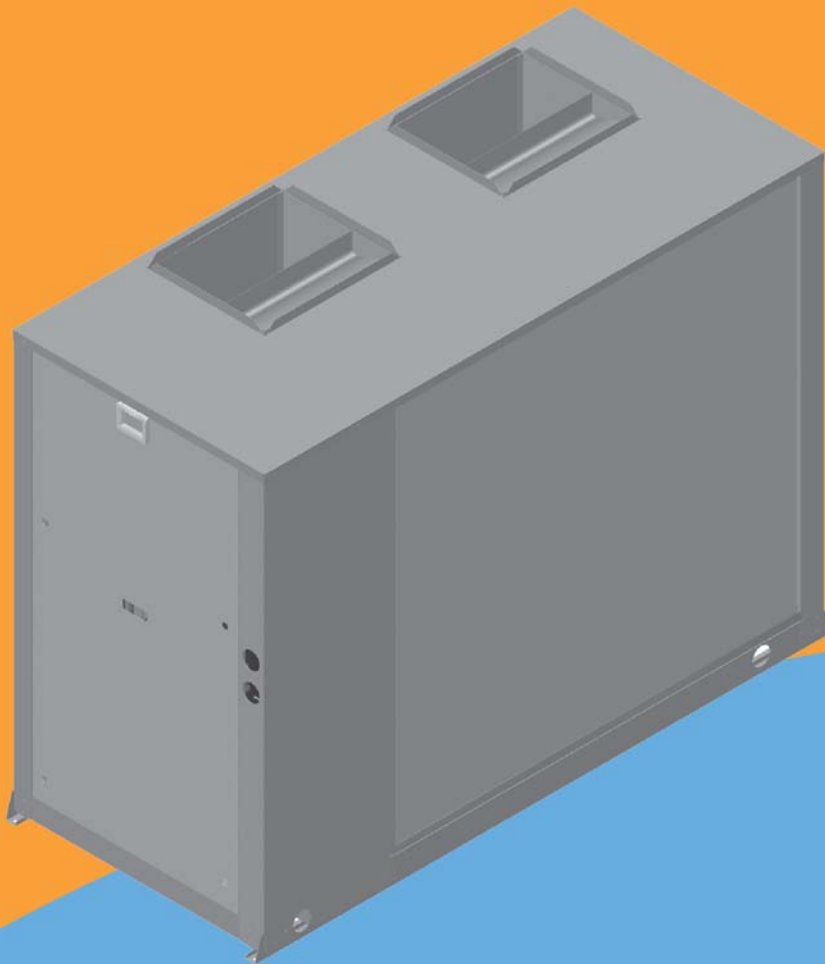

TECHNICAL MANUAL

TABLE OF CONTENTS

THIS MANUAL IS DIVIDED INTO SECTIONS. THEIR NAMES APPEAR IN THE HEADING OF EACH PAGE.

GENERAL SPECIFICATIONS	4
PRESENTATION OF THE UNIT	4
IDENTIFICATION CODE OF THE UNIT	4
DESCRIPTION OF THE COMPONENTS	5
ACCESSORIES AND OPTIONAL EQUIPMENT	7
MECHANICAL ACCESSORIES	7
ELECTRICAL ACCESSORIES	8
MECHANICAL OPTIONS	8
ELECTRICAL OPTIONS	8
TECHNICAL SPECIFICATIONS AND STANDARD PERFORMANCES - IR R410A COOLING UNIT ONLY	9
TECHNICAL SPECIFICATIONS	9
STANDARD PERFORMANCES	10
TECHNICAL SPECIFICATIONS AND STANDARD PERFORMANCES - IP R410A HEAT PUMP UNITS	11
TECHNICAL SPECIFICATIONS	11
STANDARD PERFORMANCES IN COOLING MODE	12
STANDARD PERFORMANCES IN HEATING MODE	13
NOISE LEVELS	14
NOISE LEVELS OF IR AND IP UNIT STANDARD VERSION VB	14
NOISE LEVELS OF IR AND IP UNIT STANDARD VERSION VB + SILENCING KIT ACCESSORY KS	14
OPERATING RANGE	15
OPERATING RANGE	15
WATER PRESSURE DROP AND WORKING HEAD	16
WATER PRESSURE DROP	16
WORKING HEAD	16
MAXIMUM VOLUME OF WATER	17
MAXIMUM VOLUME OF WATER IN THE SYSTEM WITH WET MODULE	17
DIMENSIONAL DATA	18
OVERALL DIMENSIONS	18
WEIGHT UNIT	18
POSITION OF WET CONNECTIONS	19
MINIMUM SPACE REQUIRED FOR OPERATION	19

GENERAL SPECIFICATIONS

Presentation of the unit

This series of industrial refrigerators covers **6** construction sizes, available in both cold-only and heat-pump versions, with a rated refrigerating capacity of from **19.2 to 51.7 kW** (from 18.7 to 49.7 kW for the heat-pump version) and with a rated thermal power of from **20.4 to 51.3 kW**. These units are designed to satisfy the heating and cooling requirements of both residential and commercial installations of small and medium capacity. They are air condensed and suited for indoor installation. Centrifugal fans are used to expel the air drawn in by the coil. The units are fitted with the air delivery upright and the ducting can be done on the fan delivery using flanges obtained on the structure of the unit. It is also possible to duct the intake section by using a coil flange, supplied as an accessory. The framework and panelling are made of galvanized plate of a suitable thickness painted with polyurethane powders. All the fixing members are made of stainless steel and/or are galvanized. The electric panel is housed in a special compartment with protection class **IP 54**. It contains thermal and magneto-thermal protection for the most important parts and the microprocessor controller. In addition, all the units are supplied as standard with the power supply phase sequence indicator. All the units have the standard outfit of **1 SCROLL** compressor specifically designed for working with **R410A ecological refrigerant gas**. The compressor, equipped with thermal protection inside the motor and outlet overtemperature, is installed in a special compartment protected from the air flow in order to facilitate routine and special maintenance work. The exchanger on the water-refrigerant circuit, the plate type, is thermo-insulated and protected with a differential pressure switch on the water and antifreeze electric heater. The finned coil, with a large surface area for thermal exchange, is composed of copper pipes and notched aluminium fins. Centrifugal fans with fan wheel having blades facing forwards are coupled to the motor with a belt drive and pulleys. All the units permit producing cold water from **5 to 12°C** (summer operation) and hot water from **35 to 50°C** (winter operation, for Heat Pumps only IP). The standard outfit can be supplemented with a vast range of accessories. Especially noteworthy:- Silencing Kit (KS), composed of lagging the refrigerator circuit compartment and the compressor with soundproofing material, enables reducing the level of noise emitted by the unit by approximately 3 dB. - Storage and Pumping Module (MAP), composed of a Pumping Module and the Water Storage Tank. The Storage Tank is always configured for storage on the delivery to the system. The Pumping Module is available with 1 pump and equipped with all the plumbing components needed for complete installation. All the units are carefully built and tested one by one. Installation merely requires the electrical and plumbing connections, expelled air ducting and, where necessary, intake air ducting.



Identification code of the unit

The codes that identify the units are listed below and include the sequences of letters that determine the meanings for the various versions and set-ups.

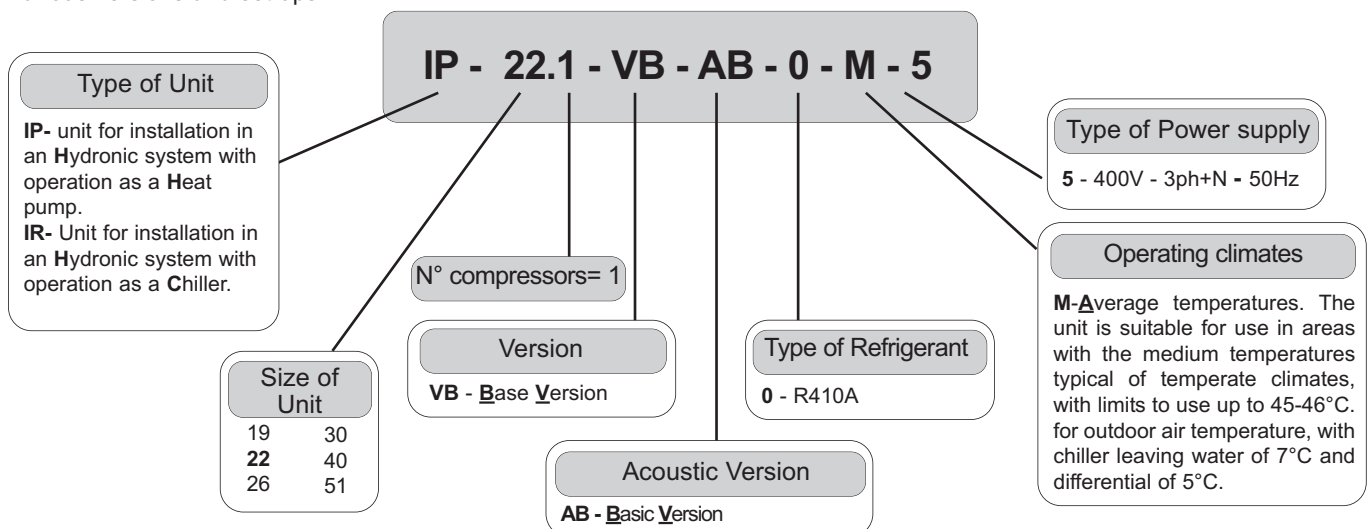

GENERAL SPECIFICATIONS

Description of the components

The technical features of the main components in the units are: (Fig. 1).

1. **Fans.** It is composed of a pair of dual-intake centrifugal fans with blades curved forwards, balanced both statically and dynamically in compliance with ISO 1940 class 6.3 standards. The screw conveyor, rotor and frame are made of galvanized plate, while the shaft is made of C40 steel. The fan is coupled via belt and pulleys to a 4-pole, three-phase, asynchronous motor secured on a special tightener slide, with protection class IP55, insulation class F and suitable for continuous service (S1) with sufficient thermal margin in the event of overloads of limited duration. The pulley fitted on the motor has a variable diameter and, within certain limits, enables adjusting the speed of rotation of the fan in order to obtain the desired air flow rate and useful head values.

2. **Electric control and monitoring panel.** This is housed in a metal casing in which the various electrical components are positioned on one metal plate.

a. The main components are:

- Main door-locking circuit-breaker.
- Power supply phase sequence meter and monitor
- Compressor protection fuses
- Compressor contactor
- Fuse to protect the resistors (casing and antifreeze)
- Insulating and safety transformer to power the auxiliary circuit and controller board, protected by a fuse.
- Magneto-thermal protection and fan motor contactor
- Wiring board
- Fan speed control board.

b. The monitoring section includes:

- User interface terminal with LCD
- On-off key.
- Operating mode selector key.
- Compressor on-off LED.
- Antifreeze heaters on LED.
- Defrosting request/activation LED
- Check-control with fault code display.

The main functions of the monitoring system are:

- Water temperature regulation
- Compressor operating hour count (display protected by a **PASSWORD** only accessible to assistance service staff)
- Start-up time settings
- Parameter entry via the keyboard
- Functions associated with the digital inputs
 - High and low pressure
 - Fan motor
 - Compressor protection
 - Thermal protection of fans
 - Differential pressure switch on wet side
 - Remote ON/OFF command
 - Remote controlled operating mode changes (heating/cooling)
 - Pump protection
- Functions associated with the digital outputs
 - Compressor control
 - Cycle reversing valve (for heat pump only)
 - Antifreeze heating element
 - Water circulating pump control
 - General remote alarm
- Functions associated with the analog inputs
 - Water inlet and outlet temperature
 - Temperature of the coils

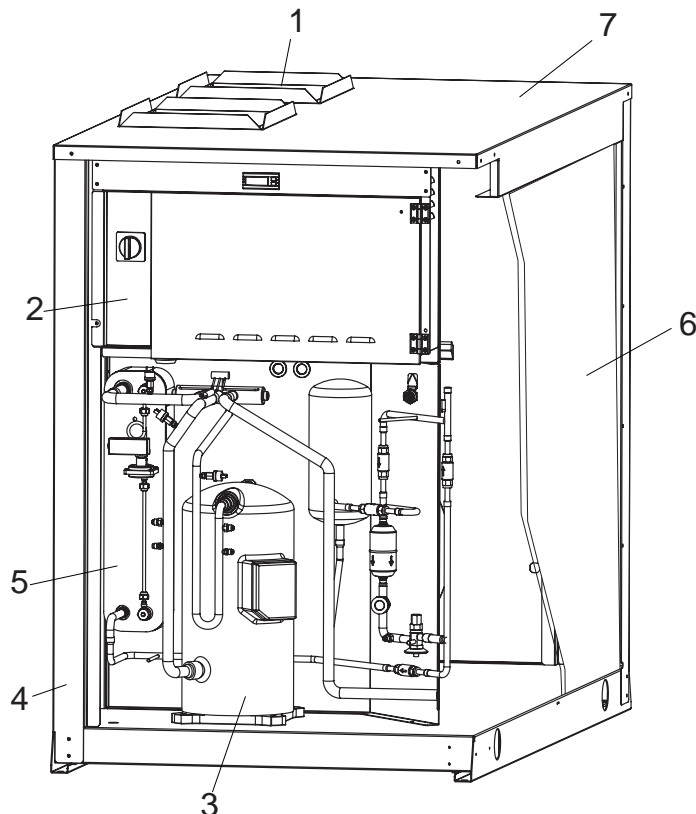

Fig. 1

GENERAL SPECIFICATIONS

3. **Compressor**, of the **SCROLL** type with an orbiting spiral equipped with thermal protection and oil heater. For the silenced version AS there is a soundproofing jacket and the entire compressor compartment is soundproofed to reduce noise emissions. The internal protection shuts down the compressor in cases of overtemperature of the motor windings and/or delivery gas.
4. Bearing structure made of galvanized sheet metal panels coated with polyurethane powder paint to ensure good protection against adverse weather conditions. **The unit is supplied with coil air intake flanges (supplied).**
5. Plate-type evaporator made of braze-welded stainless steel (AISI 316). It is installed within a shell of thermal barrier insulating material to prevent the formation of condensation and heat exchanges towards the outside. Standard supply also includes an antifreeze heating element and a differential pressure switch on the water supply circuit to avoid the risk of freezing if the water flow is shut off for some reason.
6. **The condensating coils** are the finned aluminium pack type with a notched profile to increase the coefficient of thermal exchange and they have copper pipes arranged in staggered rows. Only for the heat pumps at the bottom there is a galvanized sheet metal tray to collect the condensation fitted with a water drain union (1/2" GAS M).
7. **The covering panels** are made of galvanized plate and painted with polyurethane powders to provide good resistance to dirt and moisture.
8. **The high pressure switch**, with a fixed setting, is installed on the delivery pipe and shuts down the compressor if the working pressure is higher than permissible. If it trips, the unit shuts down and can only restart by resetting with the user interface terminal.

9. **The low pressure switch**, with a fixed setting, is installed on the suction pipe and shuts down the compressor if the working pressure is lower than permissible. It is automatically restored when the pressure increases. If it trips frequently, the unit shuts down and can only restart by resetting with the user interface terminal.
9. **The low pressure switch (IP units only)**, with a fixed setting, is installed on the plate exchanger and shuts down the compressor if the working pressure is lower than permissible. It is automatically restored when the pressure increases. If it trips frequently, the unit shuts down and can only restart by resetting with the user interface terminal.

10. **The liquid and moisture flow indicator** signals the medium flowing in the circuit, indicating the correct cooling load. The fluid gauge moreover signals the moisture content of the refrigerant by changing its colour.

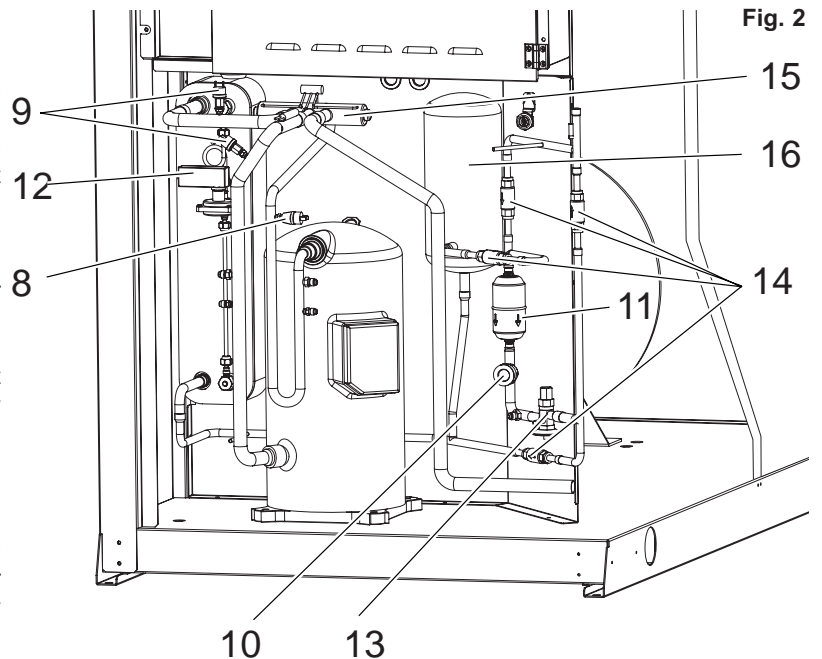

11. **The dewatering filter**, mechanical type, is used to hold back debris and any traces of moisture in the circuit.
12. **The water differential pressure switch** is supplied as standard and installed on the connections between the exchanger water inlet and outlet. If it trips frequently, the unit shuts down and can only restart by resetting with the user interface terminal.
13. **Thermostatic valve**, type with external balancer. It's job is to supply the evaporator correctly, keeping the set level of overheating constant.
For some models there are 2 thermostatic valves for cooling operation and one for heating operation.
14. **Check valves (IP units only)** allow the refrigerant to be forced to pass through the appropriate exchangers according to the operating cycle.
15. **The 4-way cycle inversion valve (IP units only)** reverses the direction of flow of refrigerant as summer/winter operation is changed over.
16. **The medium receiver (IP units only)** is a storage tank to limit the changes in cooling load required by the machine as summer/winter operation is changed over.

ACCESSORIES AND OPTIONAL EQUIPMENT

Mechanical accessories

GM - Pressure gauges. Consisting of 2 pressure gauges that display the pressure of the refrigerant fluid on the compressor's intake and delivery.

GP - Protective grilles. Consisting of metal grilles that protect the coils with extended surfaces.

AVG - Rubber vibration dampers. Consisting of 4 rubber vibration dampers to fix under the unit. They reduce the mechanical vibrations generated by the compressor and fan/s during their normal operation, that are transmitted to the bearing surface of the machine. The insulation degree provided by the vibration dampers is about 90%.

KS - Silencing Kit, composed of the lagging of the refrigerating circuit compartment and the compressor with soundproofing material that, enables reducing the level of noise emitted by the unit under nominal conditions by approximately 3dB.

KT - Tube Kit is composed of two steel pipes insulated with heatproofing material and enables taking the water IN / OUT connections onto the machine.

MAP - Storage and Pumping Module, composed of a Pumping Module and the Water Storage Tank.

The Storage Tank is always configured for storage on the delivery to the system. The Pumping Module is available with 1 pump and equipped with all the plumbing components (water filter, expansion tank, shut-off valves, safety valve, air vent, water drain) needed for complete and easily serviceable installation. The pump draws water from the system, sends it to the plate exchanger and then to the inertial storage tank. In this configuration, under nominal operating conditions, the pump is able to supply a residual head to the circulating water that depending on the model and version goes from 72 to 126 kPa (7.2/12.6 m.w.c.).

The accessory is composed of:

1 Hydraulic pump. Used to make the water circulate in the system. The pumps with a steel impeller have a high head and enable satisfying most plant engineering situations. The pump is protected by a motor cut-out fitted in the electric panel of the cooler. The pump is equipped with two 1/4" gas plugs to enable filling with water / venting air (top plug) and perfectly draining off pump water (bottom plug).

2 Water Storage Tank: comprehensive of antifreeze resistor connection. It is made of painted metal plate of suitable thickness, enables decreasing the number of pick-ups of the compressor and the fluctuations in the temperature of the water sent to the users. Insulated with heatproofing material to prevent condensation and heat exchange with the outside. It is always configured for storage on the delivery to the system.

3 Water safety valve. Located on the back of the tank, it is able to trip in the event of any service trouble generating working pressure for the plumbing system greater than the valve opening value.

MAP - Storage and Pumping Module

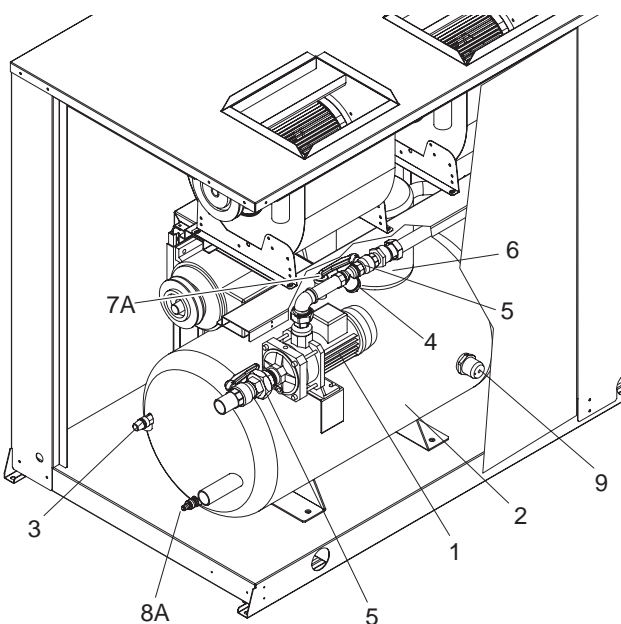

KT - Tube Kit

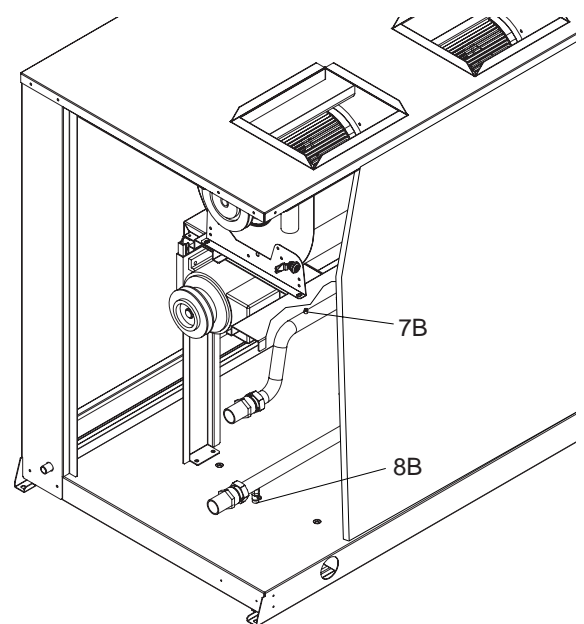

ACCESSORIES AND OPTIONAL EQUIPMENT

4 Water filter with metal cartridge. It can be shut off and inspected and is located on the plate exchanger inlet pipe; it prevents any machining debris (powder, shavings, etc.) that could be present in the water piping from getting into the plate exchanger.

5 On-off ball valves. They are used to shut off components such as the water filter and pump that need routine or special maintenance.

6 Expansion tank. This is a diaphragm closed expansion tank; it is used to absorb changes in volume of the water in the system due to changes in temperature.

7 Air vent. Accessible by removing the rear panel positioned on the opposite side of the unit to the electrical panel and the side panel, it is composed of 1 automatic valve (7A), located on the tank, and 2 manual valves (7B), positioned on the top of the hydraulic pipes.

8 Water drain. Shut off by a cock that can be reached by removing the upper rear panel, one is located on the bottom of the tank (8A) and a second one on the bottom pipe of the plate exchanger (8B).

9 Antifreeze heater connection. Female 1"1/4 threaded connection, fitted for inserting the tank antifreeze heater.

Electrical accessories

CR - Remote control. This can be used to select all the monitoring and display functions of the control unit on the machine at a maximum distance of 100 meters away. It must be installed by using a cable with three strands or three wires in **PVC** of the **N07-VK** type with a 1mm² section. The transmission line must be installed in a raceway separate from any electric powering wires (**230/400 V**).

The control unit has the following buttons:



MODE key : used to select the operating mode

ON/OFF key : used to turn the unit ON/OFF and to reset the alarms

Mode + ON/OFF keys : used to access and quit the various menu levels

UP key: scrolls forwards through the menu items or increases the value of a parameter

Tasto DOWN: scrolls backwards through the menu items or decreases the value of a parameter.

OP - Programmer clock. Allows the unit to be turned on and off depending on the programmed time setting (up to 14 switching actions can be programmed as required throughout the 7 days of the week).

RAG: Antifreeze heating element for the accumulation tank. Plug type. This activates in parallel with the evaporator's anti-freeze heating element and keeps the water at a temperature able to prevent ice from forming when the unit remains idle during the winter.

INT - RS485 serial interface, for communications via MODBUS protocol.

Condensation control accessories

These devices allow the unit to work at low air temperatures when cooling (condensation control) and at high air temperatures when heating (evaporation control).

IMV - Fan Motor Inverter. It is composed of an inverter that modulates the speed of rotation of the fan and therefore the air flow rate in the coil in order to maintain an adequate condensation/evaporation pressure.

This device moreover enables adjusting the residual static pressure actually needed to overcome the head losses of the ducting by setting the corresponding parameter with the keypad, without needing to change belts and pulleys.

SMV - Fan Delivery Gate. It is composed of a gate with a servo motor to be installed on the fan outlet: depending on the temperature read by the coil sensor, the controller will modulate its opening/closing to keep the right air flow rate in the coil.

Mechanical options

Special finned heat exchangers

- Coils with copper fins
- Coils with tin-coated copper fins
- Coils with aluminium fins with acrylic coating

Electrical options

Power source voltage rating 230V-3-50Hz

TECHNICAL SPECIFICATIONS AND STANDARD PERFORMANCES - IR R410A COOLING UNIT ONLY

Technical specifications

Model	19	22	26	30	40	51	UM
Refrigerant	R410A						
Gross cooling capacity ^{(1)(E)}	19,2	22,3	26,0	29,1	40,8	51,7	kW
Gross total power input ^(E)	8,30	9,00	10,15	11,5	14,7	19,5	kW
EER ^{(1)(E)}	2,29	2,46	2,55	2,48	2,73	2,58	W/W

Compressor specifications

Type	SCROLL						
Quantity	1						N°
N° Throttling steps	0-100						%
Power input ⁽¹⁾	6,40	7,10	8,25	9,60	11,8	16,6	kW

Plate-type Heat Exchanger specifications

Quantity	1						N°
Water capacity	1.4	1.7	2.0	2.3	3.1	4.2	l
Maximum pressure on water side	100						kPa
Water flow rate	0,92	1,07	1,24	1,39	1,95	2,47	l/s
Water pressure drop ^(E)	37	33	34	34	47	43	kPa

Fan specifications

Number of fans	2						N°
Maximum rated useful head ⁽²⁾	100 / 200						Pa
Max motor input power ⁽³⁾	1.5			2.5			kW
Total air flow rate on cooling ⁽³⁾	2540	2540	2440	2440	4500	4310	l/s

Data for water storage tank and pumping module (MAP accessory)

Water capacity	140			180			l
Max. operating pressure	600						kPa
Safety valve setting	600						kPa
Surge chamber volume	8			12			l
Service charge pressure of surge chamber	150						kPa
Working head	121	112	98	81	97	72	kPa
Pump power input	0.45			0.70			kW

Electrical specifications ⁽⁴⁾

Power supply	400V - 3 ph + N - 50 Hz						V/ph/Hz
Total maximum power input [FLA]	19.5	24.5	25.5	28.5	38.0	47.0	A
Total maximum surge current [MIC]	93	109	116	116	197	224	A
Total maximum power input [FLI]	9.9	11	12.8	14.2	18.4	24	kW

NOTES:

(1): The data refer to: Water temperature: inlet: 12°C - outlet: 7°C. Outdoor air temperature 35°C D.B.

(2): Adjustable by changing the diameter on the motor pulleys.

(3): At fan's top speed

(4) At the maximum permissible operating conditions with MAP accessory.

(MAP): With Storage and Pumping Module

(E): Data certificated by **EUROVENT**

TECHNICAL SPECIFICATIONS AND STANDARD PERFORMANCES - IR R410A COOLING UNIT ONLY

Standard performances

MODEL	Tw	OUTDOOR AIR TEMPERATURE (°C B.S.)											
		20		25		30		35		40		45	
		kWf	kWa	kWf	kWa	kWf	kWa	kWf	kWa	kWf	kWa	kWf	kWa
19	5	20,9	5,2	20,1	5,6	19,2	6,0	18,4	6,3	17,0	7,1	15,5	7,9
	6	21,3	5,2	20,4	5,6	19,6	6,0	18,8	6,4	17,3	7,1	15,9	7,9
	7	21,7	5,2	20,9	5,6	20,0	6,0	19,2	6,4	17,8	7,2	16,3	7,9
	8	22,2	5,3	21,3	5,7	20,5	6,0	19,7	6,4	18,2	7,2	16,8	8,0
	9	22,6	5,3	21,8	5,7	21,0	6,1	20,1	6,5	18,7	7,2	17,3	8,0
	10	23,1	5,3	22,2	5,7	21,4	6,1	20,6	6,5	19,1	7,3	17,7	8,0
	11	23,5	5,4	22,7	5,8	21,9	6,1	21,0	6,5	19,6	7,3	18,1	8,1
	12	24,0	5,4	23,1	5,8	22,3	6,2	21,5	6,6	20,0	7,3	18,6	8,1
22	5	24,3	5,8	23,3	6,2	22,3	6,6	21,4	7,0	19,7	7,9	18,0	8,7
	6	24,7	5,8	23,7	6,2	22,8	6,6	21,8	7,1	20,1	7,9	18,5	8,8
	7	25,2	5,8	24,2	6,2	23,3	6,7	22,3	7,1	20,6	8,0	19,0	8,8
	8	25,7	5,9	24,8	6,3	23,8	6,7	22,8	7,1	21,2	8,0	19,5	8,8
	9	26,3	5,9	25,3	6,3	24,3	6,7	23,4	7,2	21,7	8,0	20,0	8,9
	10	26,8	5,9	25,8	6,4	24,9	6,8	23,9	7,2	22,2	8,1	20,6	8,9
	11	27,3	6,0	26,4	6,4	25,4	6,8	24,4	7,2	22,8	8,1	21,1	8,9
	12	27,8	6,0	26,9	6,4	25,9	6,9	24,9	7,3	23,3	8,1	21,6	9,0
26	5	28,3	6,7	27,2	7,2	26,0	7,7	24,9	8,2	23,0	9,2	21,0	10,1
	6	28,8	6,7	27,7	7,2	26,6	7,7	25,4	8,2	23,5	9,2	21,5	10,2
	7	29,4	6,8	28,3	7,3	27,1	7,8	26,0	8,3	24,1	9,2	22,1	10,2
	8	30,0	6,8	28,9	7,3	27,8	7,8	26,6	8,3	24,7	9,3	22,7	10,3
	9	30,6	6,8	29,5	7,3	28,4	7,8	27,3	8,3	25,3	9,3	23,4	10,3
	10	31,3	6,9	30,1	7,4	29,0	7,9	27,9	8,4	25,9	9,4	24,0	10,4
	11	31,9	6,9	30,7	7,4	29,6	7,9	28,5	8,4	26,5	9,4	24,6	10,4
	12	32,5	7,0	31,3	7,5	30,2	8,0	29,1	8,5	27,1	9,4	25,2	10,4
30	5	31,7	7,8	30,4	8,4	29,1	8,9	27,9	9,5	25,7	10,7	23,5	11,8
	6	32,2	7,8	31,0	8,4	29,7	9,0	28,5	9,6	26,3	10,7	24,1	11,9
	7	32,9	7,9	31,6	8,4	30,4	9,0	29,1	9,6	26,9	10,8	24,7	11,9
	8	33,6	7,9	32,3	8,5	31,1	9,1	29,8	9,6	27,6	10,8	25,4	12,0
	9	34,3	8,0	33,0	8,5	31,8	9,1	30,5	9,7	28,3	10,8	26,1	12,0
	10	35,0	8,0	33,7	8,6	32,5	9,2	31,2	9,7	29,0	10,9	26,8	12,0
	11	35,7	8,1	34,4	8,6	33,1	9,2	31,9	9,8	29,7	10,9	27,5	12,1
	12	36,3	8,1	35,1	8,7	33,8	9,3	32,5	9,8	30,4	11,0	28,2	12,1
40	5	44,4	9,6	42,6	10,3	40,9	11,0	39,1	11,7	36,0	13,1	33,0	14,5
	6	45,2	9,6	43,4	10,3	41,7	11,0	39,9	11,7	36,8	13,2	33,8	14,6
	7	46,1	9,7	44,3	10,4	42,6	11,1	40,8	11,8	37,7	13,2	34,7	14,6
	8	47,1	9,7	45,3	10,4	43,6	11,2	41,8	11,9	38,7	13,3	35,7	14,7
	9	48,1	9,8	46,3	10,5	44,5	11,2	42,8	11,9	39,7	13,3	36,7	14,8
	10	49,0	9,9	47,3	10,6	45,5	11,3	43,7	12,0	40,7	13,4	37,6	14,8
	11	50,0	9,9	48,2	10,6	46,5	11,3	44,7	12,0	41,6	13,5	38,6	14,9
	12	50,9	10,0	49,2	10,7	47,4	11,4	45,6	12,1	42,6	13,5	39,5	14,9
51	5	56,2	13,4	54,0	14,4	51,8	15,4	49,5	16,4	45,7	18,4	41,8	20,4
	6	57,3	13,5	55,0	14,5	52,8	15,5	50,6	16,5	46,7	18,5	42,8	20,5
	7	58,4	13,6	56,2	14,6	53,9	15,6	51,7	16,6	47,8	18,6	43,9	20,6
	8	59,7	13,7	57,4	14,7	55,2	15,7	53,0	16,7	49,1	18,7	45,2	20,7
	9	60,9	13,8	58,7	14,8	56,4	15,8	54,2	16,8	50,3	18,8	46,5	20,8
	10	62,1	13,9	59,9	14,9	57,7	15,9	55,4	16,8	51,5	18,8	47,7	20,8
	11	63,3	13,9	61,1	14,9	58,9	15,9	56,6	16,9	52,7	18,9	48,9	20,9
	12	64,5	14,0	62,3	15,0	60,1	16,0	57,8	17,0	53,9	19,0	50,1	21,0

Tw= Outlet water temperature °C

kWf = Net refrigerating power (kW).

kWa = Power input of compressors (kW)

The standard performances refer to a 5°C temperature difference between the water entering and leaving the plate-type heat exchanger and to operation of the unit with all fans at top speed. A $0.44 \times 10^{-4} \text{ m}^2 \text{ K/W}$ fouling factor has also been considered with the unit installed at zero meters above sea level (Pb = 1013mbar).

TECHNICAL SPECIFICATIONS AND STANDARD PERFORMANCES - IP R410A HEAT PUMP UNITS

Technical specifications

Model	19	22	26	30	40	51	UM	
Refrigerant	R410A							
Gross cooling capacity ^{(1)(E)}	18,7	21,9	25,6	28,2	39,1	49,7	kW	
Gross heating capacity ^{(2)(E)}	20,4	23,5	27,6	29,4	41,0	51,3	kW	
Gross total power input ^(E)	In cooling mode ⁽¹⁾	8,15	8,90	10,05	11,35	14,3	19,3	kW
	In heating mode ⁽²⁾	8,2	9,0	10,3	11,0	14,7	18,4	kW
EER ^{(1)(E)}	2,31	2,48	2,56	2,53	2,78	2,65	W/W	
COP ^{(2)(E)}	2,5	2,6	2,7	2,7	2,8	2,8	W/W	

Compressor specifications

Tipo	SCROLL							
Quantità	1							N°
Gradini di parzializzazione	0-100							%
Potenza assorbita	In cooling mode ⁽¹⁾	6,25	7,00	8,15	9,45	11,4	16,4	kW
	In heating mode ⁽²⁾	6,30	7,10	8,40	9,10	11,8	15,5	kW

Plate-type Heat Exchanger specifications

Quantity	1							N°
Water capacity	1.4	1.7	2.0	2.3	3.1	4.2	l	
Maximum pressure on water side	100							kPa
In cooling mode ⁽¹⁾	Water flow rate	0,89	1,05	1,22	1,35	1,87	2,37	l/s
	Water pressure drop(E)	35	32	33	32	43	40	kPa
In heating mode ⁽²⁾	Water flow rate	0,97	1,12	1,32	1,40	1,96	2,45	l/s
	Water pressure drop(E)	42	37	38	35	47	43	kPa

Fan specifications

Number of fans	2							N°
Maximum rated useful head ⁽³⁾	100 / 200							Pa
Max motor input power ⁽⁴⁾	1.5				2.5			kW
Total air flow rate on cooling ⁽⁴⁾	2540	2540	2440	2440	4500	4310	l/s	
Total air flow rate on heating ⁽⁴⁾	2430	2430	2340	2340	4310	4310	l/s	

Data for water storage tank and pumping module (MAP accessory)

Water capacity	140				180			l
Max. operating pressure	600							kPa
Safety valve setting	600							kPa
Surge chamber volume	8				12			l
Service charge pressure of surge chamber	150							kPa
Working head	In cooling mode ⁽¹⁾	126	115	101	87	105	82	kPa
	In heating mode ⁽²⁾	112	104	85	79	95	74	kPa
Pump power input	0.45				0.70			kW

Electrical specifications ⁽⁵⁾

Power supply	400V - 3 ph + N - 50 Hz							V/ph/Hz
Total maximum power input [FLA]	19.5	24.5	25.5	28.5	38.0	47.0	A	
Total maximum surge current [MIC]	93	109	116	116	197	224	A	
Total maximum power input [FLI]	9.9	11	12.8	14.2	18.4	24	kW	

Notes:

- (1): The data refer to: Water temperature: inlet: 12°C - outlet: 7°C. Outdoor air temperature 35°C D.B.
 (2): The data refer to: Water temperature: inlet: 40°C - outlet: 45°C. Outdoor air temperature 7°C D.B., 6°C W.B.
 (3): Adjustable by changing the diameter on the motor pulleys.
 (4): At fan's top speed
 (5): At the maximum permissible operating conditions with MAP accessory.
(MAP): Con Modulo di Accumulo a Pompaggio
(E):Data certificated by **EUROVENT**

TECHNICAL SPECIFICATIONS AND STANDARD PERFORMANCES - IP R410A HEAT PUMP UNITS

Standard performances in cooling mode

MODEL	Tw	OUTDOOR AIR TEMPERATURE (°C B.S.)											
		20		25		30		35		40		45	
		kWf	kWa	kWf	kWa	kWf	kWa	kWf	kWa	kWf	kWa	kWf	kWa
19	5	20,3	5,1	19,5	5,4	18,7	5,8	17,9	6,2	16,5	6,9	15,1	7,7
	6	20,7	5,1	19,9	5,5	19,1	5,8	18,3	6,2	16,9	7,0	15,5	7,7
	7	21,1	5,1	20,3	5,5	19,5	5,9	18,7	6,3	17,3	7,0	15,9	7,8
	8	21,6	5,2	20,8	5,5	20,0	5,9	19,2	6,3	17,8	7,0	16,4	7,8
	9	22,0	5,2	21,2	5,6	20,4	5,9	19,6	6,3	18,2	7,1	16,8	7,8
	10	22,5	5,2	21,7	5,6	20,9	6,0	20,0	6,3	18,6	7,1	17,2	7,8
	11	22,9	5,3	22,1	5,6	21,3	6,0	20,5	6,4	19,1	7,1	17,7	7,9
	12	23,3	5,3	22,5	5,7	21,7	6,0	20,9	6,4	19,5	7,2	18,1	7,9
22	5	23,8	5,7	22,9	6,1	21,9	6,5	21,0	6,9	19,3	7,8	17,7	8,6
	6	24,3	5,7	23,3	6,1	22,4	6,5	21,4	7,0	19,8	7,8	18,1	8,6
	7	24,7	5,7	23,8	6,2	22,8	6,6	21,9	7,0	20,3	7,8	18,6	8,7
	8	25,3	5,8	24,3	6,2	23,4	6,6	22,4	7,0	20,8	7,9	19,2	8,7
	9	25,8	5,8	24,9	6,2	23,9	6,7	23,0	7,1	21,3	7,9	19,7	8,8
	10	26,3	5,8	25,4	6,3	24,4	6,7	23,5	7,1	21,8	7,9	20,2	8,8
	11	26,8	5,9	25,9	6,3	24,9	6,7	24,0	7,1	22,3	8,0	20,7	8,8
	12	27,3	5,9	26,4	6,3	25,4	6,8	24,5	7,2	22,8	8,0	21,2	8,9
26	5	27,9	6,6	26,7	7,1	25,6	7,6	24,5	8,1	22,6	9,0	20,7	10,0
	6	28,4	6,6	27,3	7,1	26,1	7,6	25,0	8,1	23,1	9,1	21,2	10,1
	7	28,9	6,7	27,8	7,2	26,7	7,7	25,6	8,2	23,7	9,1	21,8	10,1
	8	29,6	6,7	28,4	7,2	27,3	7,7	26,2	8,2	24,3	9,2	22,4	10,1
	9	30,2	6,8	29,1	7,3	28,0	7,7	26,8	8,2	24,9	9,2	23,0	10,2
	10	30,8	6,8	29,7	7,3	28,6	7,8	27,4	8,3	25,5	9,3	23,6	10,2
	11	31,4	6,8	30,3	7,3	29,1	7,8	28,0	8,3	26,1	9,3	24,2	10,3
	12	32,0	6,9	30,8	7,4	29,7	7,9	28,6	8,4	26,7	9,3	24,8	10,3
30	5	30,7	7,7	29,5	8,2	28,2	8,8	27,0	9,4	24,9	10,5	22,8	11,6
	6	31,2	7,7	30,0	8,3	28,8	8,8	27,6	9,4	25,5	10,5	23,3	11,7
	7	31,9	7,7	30,6	8,3	29,4	8,9	28,2	9,5	26,1	10,6	24,0	11,7
	8	32,6	7,8	31,3	8,4	30,1	8,9	28,9	9,5	26,8	10,6	24,7	11,8
	9	33,2	7,8	32,0	8,4	30,8	9,0	29,6	9,5	27,5	10,7	25,3	11,8
	10	33,9	7,9	32,7	8,5	31,5	9,0	30,2	9,6	28,1	10,7	26,0	11,9
	11	34,6	7,9	33,3	8,5	32,1	9,1	30,9	9,6	28,8	10,8	26,7	11,9
	12	35,2	8,0	34,0	8,6	32,8	9,1	31,5	9,7	29,4	10,8	27,3	12,0
40	5	42,5	9,2	40,8	9,9	39,2	10,6	37,5	11,3	34,5	12,7	31,6	14,0
	6	43,3	9,3	41,6	10,0	39,9	10,7	38,2	11,3	35,3	12,7	32,4	14,1
	7	44,2	9,3	42,5	10,0	40,8	10,7	39,1	11,4	36,2	12,8	33,2	14,1
	8	45,1	9,4	43,4	10,1	41,8	10,8	40,1	11,5	37,1	12,8	34,2	14,2
	9	46,1	9,5	44,4	10,1	42,7	10,8	41,0	11,5	38,1	12,9	35,1	14,3
	10	47,0	9,5	45,3	10,2	43,6	10,9	41,9	11,6	39,0	12,9	36,1	14,3
	11	47,9	9,6	46,2	10,3	44,5	10,9	42,8	11,6	39,9	13,0	37,0	14,4
	12	48,8	9,6	47,1	10,3	45,4	11,0	43,7	11,7	40,8	13,1	37,9	14,4
51	5	54,1	13,3	51,9	14,3	49,8	15,3	47,6	16,2	43,9	18,2	40,2	20,2
	6	55,1	13,4	52,9	14,4	50,8	15,3	48,6	16,3	44,9	18,3	41,2	20,3
	7	56,2	13,4	54,0	14,4	51,9	15,4	49,7	16,4	46,0	18,4	42,2	20,3
	8	57,4	13,5	55,2	14,5	53,1	15,5	50,9	16,5	47,2	18,5	43,5	20,4
	9	58,6	13,6	56,4	14,6	54,3	15,6	52,1	16,6	48,4	18,5	44,7	20,5
	10	59,7	13,7	57,6	14,7	55,4	15,7	53,3	16,6	49,6	18,6	45,8	20,6
	11	60,9	13,8	58,7	14,8	56,6	15,7	54,4	16,7	50,7	18,7	47,0	20,7
	12	62,0	13,9	59,9	14,8	57,7	15,8	55,6	16,8	51,8	18,8	48,1	20,7

Tw = Outlet water temperature °C

kWf = Net refrigerating power (kW).

kWa = Power input of compressors (kW)

The standard performances refer to a 5°C temperature difference between the water entering and leaving the plate-type heat exchanger and to operation of the unit with all fans at top speed. A $0.44 \times 10^{-4} \text{ m}^2 \text{ K/W}$ fouling factor has also been considered with the unit installed at zero meters above sea level (Pb = 1013mbar).

TECHNICAL SPECIFICATIONS AND STANDARD PERFORMANCES - IP R410A HEAT PUMP UNITS

Standard performances in heating mode

MODEL	Tw	OUTDOOR AIR TEMPERATURE (°C B.U.)													
		-6		-2		2		6		9		12		15	
		kWf	kWa	kWf	kWa	kWf	kWa	kWf	kWa	kWf	kWa	kWf	kWa	kWf	kWa
19	30	17,9	4,4	19,5	4,5	21,0	4,5	22,4	4,6	23,2	4,7	23,8	4,7	24,4	4,8
	35	17,1	4,9	18,7	5,0	20,3	5,1	21,7	5,2	22,4	5,2	23,1	5,3	23,6	5,3
	40	16,4	5,3	18,1	5,4	19,6	5,5	21,0	5,6	21,7	5,7	22,4	5,7	23,0	5,8
	45	15,8	6,0	17,4	6,1	19,0	6,2	20,4	6,3	21,1	6,4	21,8	6,4	22,4	6,5
	50	15,1	6,6	16,7	6,7	18,3	6,8	19,7	6,9	20,4	7,0	21,1	7,1	21,6	7,2
22	30	20,6	4,9	22,4	5,0	24,2	5,1	25,9	5,2	26,7	5,2	27,4	5,3	28,1	5,4
	35	19,7	5,5	21,6	5,6	23,3	5,7	25,0	5,8	25,8	5,9	26,6	5,9	27,2	6,0
	40	18,9	6,0	20,8	6,1	22,6	6,2	24,2	6,3	25,0	6,4	25,8	6,4	26,5	6,5
	45	18,2	6,7	20,1	6,9	21,9	7,0	23,5	7,1	24,3	7,2	25,1	7,2	25,8	7,3
	50	17,4	7,4	19,3	7,6	21,0	7,7	22,7	7,8	23,5	7,9	24,3	8,0	24,9	8,1
26	30	24,2	5,8	26,4	5,9	28,4	6,0	30,4	6,1	31,3	6,2	32,2	6,3	33,0	6,3
	35	23,1	6,5	25,3	6,7	27,4	6,8	29,3	6,9	30,3	7,0	31,2	7,0	32,0	7,1
	40	22,2	7,1	24,4	7,3	26,5	7,4	28,4	7,5	29,4	7,6	30,3	7,6	31,1	7,7
	45	21,4	8,0	23,6	8,1	25,7	8,3	27,6	8,4	28,6	8,5	29,4	8,6	30,2	8,7
	50	20,4	8,8	22,6	9,0	24,7	9,1	26,6	9,2	27,6	9,4	28,5	9,4	29,3	9,6
30	30	25,7	6,3	28,1	6,4	30,3	6,5	32,3	6,6	33,4	6,7	34,3	6,8	35,2	6,9
	35	24,6	7,1	27,0	7,2	29,2	7,4	31,3	7,5	32,3	7,6	33,2	7,6	34,1	7,7
	40	23,7	7,7	26,0	7,9	28,2	8,0	30,3	8,1	31,3	8,2	32,3	8,3	33,1	8,4
	45	22,8	8,6	25,1	8,8	27,3	9,0	29,4	9,1	30,4	9,2	31,4	9,3	32,2	9,4
	50	21,8	9,5	24,1	9,7	26,3	9,9	28,4	10,0	29,4	10,1	30,3	10,2	31,2	10,4
40	30	35,9	8,2	39,2	8,4	42,2	8,5	45,1	8,6	46,5	8,7	47,8	8,8	49,0	8,9
	35	34,4	9,2	37,6	9,4	40,7	9,5	43,6	9,7	45,0	9,8	46,3	9,9	47,5	10,0
	40	33,0	10,0	36,3	10,2	39,4	10,3	42,2	10,5	43,7	10,6	45,0	10,7	46,2	10,9
	45	31,8	11,2	35,1	11,4	38,1	11,6	41,0	11,8	42,4	11,9	43,7	12,0	44,9	12,2
	50	30,3	12,3	33,6	12,6	36,7	12,8	39,6	13,0	41,0	13,1	42,3	13,2	43,5	13,4
51	30	44,9	10,7	49,0	11,0	52,8	11,1	56,4	11,3	58,2	11,5	59,9	11,5	61,4	11,7
	35	43,0	12,1	47,1	12,3	50,9	12,5	54,5	12,7	56,3	12,9	58,0	13,0	59,5	13,2
	40	41,3	13,1	45,4	13,4	49,2	13,6	52,8	13,8	54,6	14,0	56,3	14,1	57,8	14,3
	45	39,8	14,7	43,9	15,0	47,7	15,3	51,3	15,5	53,1	15,7	54,7	15,8	56,2	16,0
	50	38,0	16,2	42,1	16,5	45,9	16,8	49,5	17,1	51,3	17,3	52,9	17,4	54,4	17,6

Tw= Outlet water temperature in °C

kWf = Net heating output (kW).

kWa = Power input of compressors (kW)

The standard performances refer to a 5°C temperature difference between the water entering and leaving the plate-type heat exchanger, outdoor air with 87% relative humidity and to operation of the unit with all the fans to top speed. A 0.44 x 10⁻⁴ m² K/W fouling factor has also been considered with the unit installed at zero meters above sea level (Pb = 1013mbar).

NOTE

For air temperatures of less than 7°C, the heating capacity is declared without considering the effect of the thawing cycles, strictly correlated with the humidity in the outdoor air.

NOISE LEVELS

Noise levels of IR and IP unit Standard Version VB ^{(1)(E)}

Mod.	SWL (dB)										SPL (dBA)		
	Octave bands (Hz)								Total		1m	5m	10m
	63	125	250	500	1000	2000	4000	8000	dB	dB(A)			
19	89,0	82,0	80,0	78,5	77,0	77,0	75,5	71,0	91,0	83,5	67,4	57,4	52,0
22	90,0	82,5	80,0	78,5	77,0	77,0	75,5	71,0	91,8	83,5	67,4	57,4	52,0
26	90,0	83,0	80,0	78,5	77,0	77,0	75,5	71,0	91,8	83,5	67,4	57,4	52,0
30	90,0	83,0	80,0	78,5	77,0	77,0	75,5	71,0	91,8	83,5	67,4	57,4	52,0
40	92,0	84,0	83,0	82,0	78,5	78,0	75,0	71,0	93,8	85,0	68,4	58,7	53,4
51	92,0	84,5	83,0	82,0	78,5	78,0	75,0	71,0	93,8	85,0	68,4	58,7	53,4

(1): Water temperature: inlet 12°C - outlet 7°C. Outdoor temperature 35°C.

SWL = Sound power levels, with reference to 1×10^{-12} W.

The **Total** sound power level in **dB(A)** measured in compliance with **ISO 9614** standards, is certified according to the **Eurovent** certification program.

Eurovent certification (**E**) exclusively refers to the **Total** Sound Power in **dB(A)**, which is therefore the only binding acoustic specification (the values of the Octave bands in the table are indicative).

SPL = Sound pressure levels, with reference to 2×10^{-5} Pa.

The sound pressure levels are values calculated by applying the **ISO-3744 relation (Eurovent 8/1)** and refer to a distance of 1,5,10 meters away from the external surface of units operating in the open field with directivity factor 2 and the units operating in nominal conditions in the cooling mode.

Noise levels of IR and IP unit Standard Version VB + Silencing Kit accessory KS ^{(1)(E)}

Mod.	SWL (dB)										SPL (dBA)		
	Octave bands (Hz)								Total		1m	5m	10m
	63	125	250	500	1000	2000	4000	8000	dB	dB(A)			
19	86,0	75,5	74,5	76,0	74,0	75,0	73,5	69,0	87,7	81,0	64,9	54,9	49,5
22	86,0	75,5	74,5	76,0	74,0	75,0	73,5	69,0	87,7	81,0	64,9	54,9	49,5
26	86,0	75,5	74,5	76,0	74,0	75,0	73,5	69,0	87,7	81,0	64,9	54,9	49,5
30	86,0	75,5	74,5	76,0	74,0	75,0	73,5	69,0	87,7	81,0	64,9	54,9	49,5
40	90,0	80,0	76,5	79,0	76,0	75,0	72,5	69,0	91,2	82,0	65,4	55,7	50,4
51	90,0	80,0	77,0	79,0	76,0	75,0	72,5	69,0	91,2	82,0	65,4	55,7	50,4

(1): Water temperature: inlet 12°C - outlet 7°C. Outdoor temperature 35°C.

SWL = Sound power levels, with reference to 1×10^{-12} W.

The **Total** sound power level in **dB(A)** measured in compliance with **ISO 9614** standards, is certified according to the **Eurovent** certification program.

Eurovent certification (**E**) exclusively refers to the **Total** Sound Power in **dB(A)**, which is therefore the only binding acoustic specification (the values of the Octave bands in the table are indicative).

SPL = Sound pressure levels, with reference to 2×10^{-5} Pa.

The sound pressure levels are values calculated by applying the **ISO-3744 relation (Eurovent 8/1)** and refer to a distance of 1,5,10 meters away from the external surface of units operating in the open field with directivity factor 2 and the units operating in nominal conditions in the cooling mode.

OPERATING RANGE

Operating range

The graphs below give the operating ranges within which correct operation of the units is guaranteed. The use of the units in conditions differing from those indicated will void the warranty with which the product is supplied. In the following table, there are the thermal water head limit values of the unit.

Thermal Water Head		Limit value
Minimun	°C	3
Maximus	°C	8

COOLING MODE

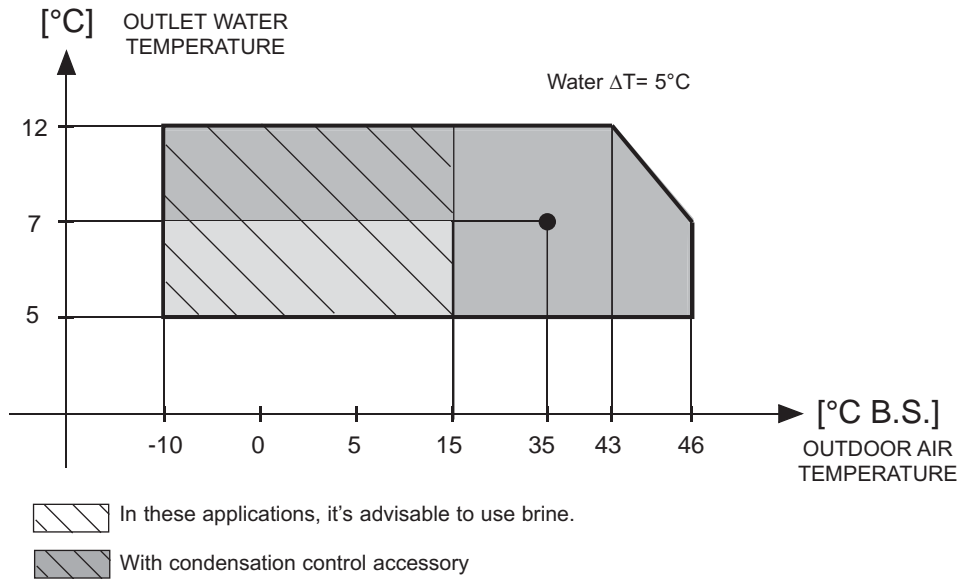

HEATING MODE

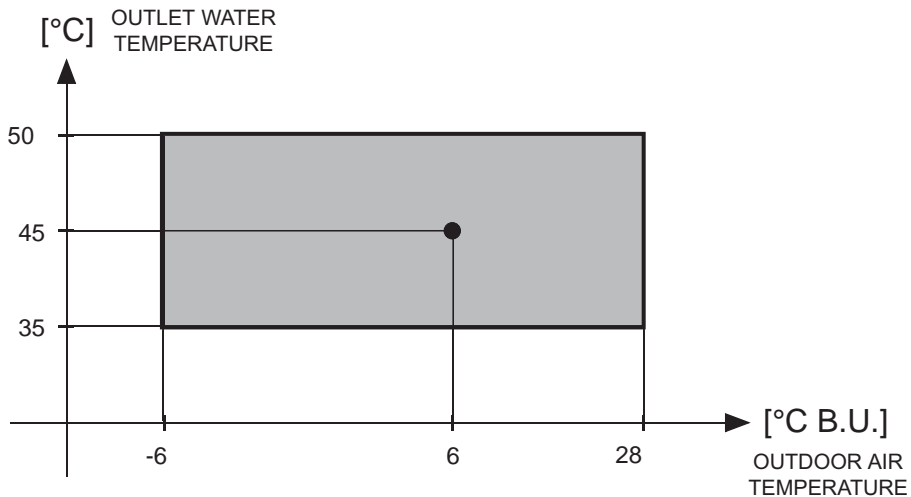

WATER PRESSURE DROP AND WORKING HEAD

Water pressure drop

The graph below illustrates the water pressure drop values in **kPa** depending on the flow rate in **liters/second**. The operating range is delimited by the minimum and maximum values given in the next table.

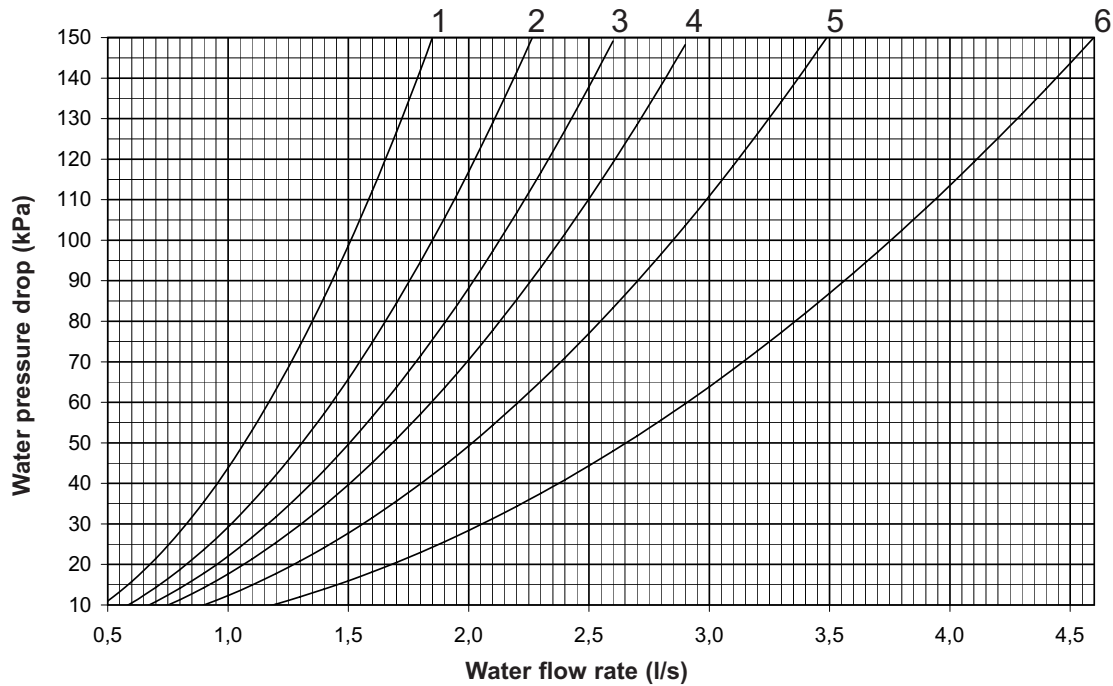

Working head

The following graph gives the head values (**kPa**) depending on the water flow rate (**liters/second**). The operating range is delimited by the minimum and maximum values given in the next table.

Working head is the one on the wet module outlet minus all the water pressure drop of the unit.

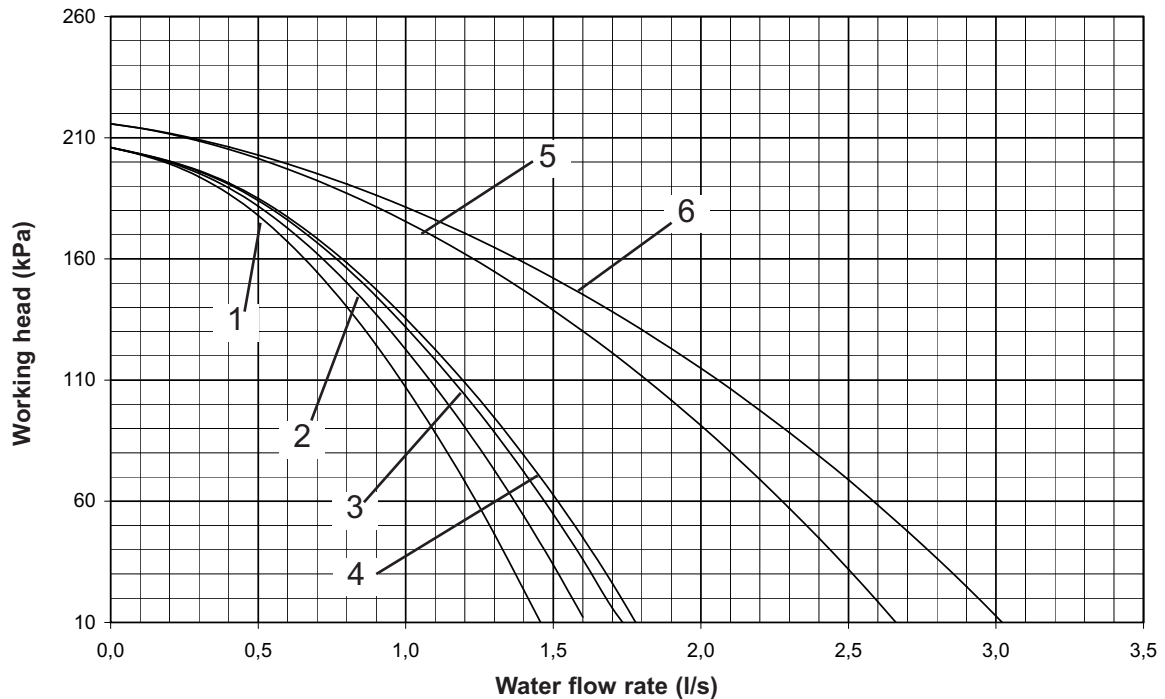

Limits to operation

Model	19	22	26	30	40	51	UM	NOTES
Graph reference	1	2	3	4	5	6		Q= Water flow rate
Lower limit value	Q	0.5	0.6	0.7	0.8	0.9	1.2	l/s
Upper limit value	Q	1.8	2.25	2.6	2.9	3.5	4.6	l/s

MAXIMUM VOLUME OF WATER

Maximum volume of water in the system with wet module

Before filling the water system, it is advisable to consider the type of installation in question, i.e. check the difference in level between the wet module and user. The following table gives the maximum water content of the water supply system in liters, depending on the capacity of the standard surge chamber supplied and the pressure at which it should be charged. The surge chamber setting must be regulated to suit the maximum positive difference in level of the user.

Maximum setting value **600 kPa**.

With a positive H of more than 12.25 meters, calculate the surge chamber's service charge value in kPa using the formula below:

$$\text{Surge chamber service charge} = [H/10.2 + 0.3] \times 100 = [\text{kPa}]$$

NOTE: In case A, make sure that the user's lowest point is able to withstand the global pressure.

Tab.1

Model		19 - 22 - 26 - 30	40 - 51			
Surge chamber volume (liters)		8	12			
Thermal expansion of water (10-40°C)		0.0074				
Thermal expansion of water (10-60°C)		0.0167				
H (meters)		Surge chamber pressure (kPa)	Maximum total volume of water supply system (liters)			
			IR	IP	IR	IP
Case A	H < 0	150 (standard)	695	308	1043	462
	0 < H < 12.25	150 (standard)	695	308	1043	462
Case B	20	226	577	256	866	384
	25	275	502	222	753	333
	30	324	426	189	639	284

NOTE: If the unit operates with brine, calculate the real volume of the system by taking into account the corrective factors for the volume of the system given in the table below.

Corrective factors per total maximum volume of the system with brine

% of brine	0%	10%	20%	30%	40%
Cooling Mode	1.000	0.738	0.693	0.652	0.615
Heating Mode	1.000	0.855	0.811	0.769	0.731

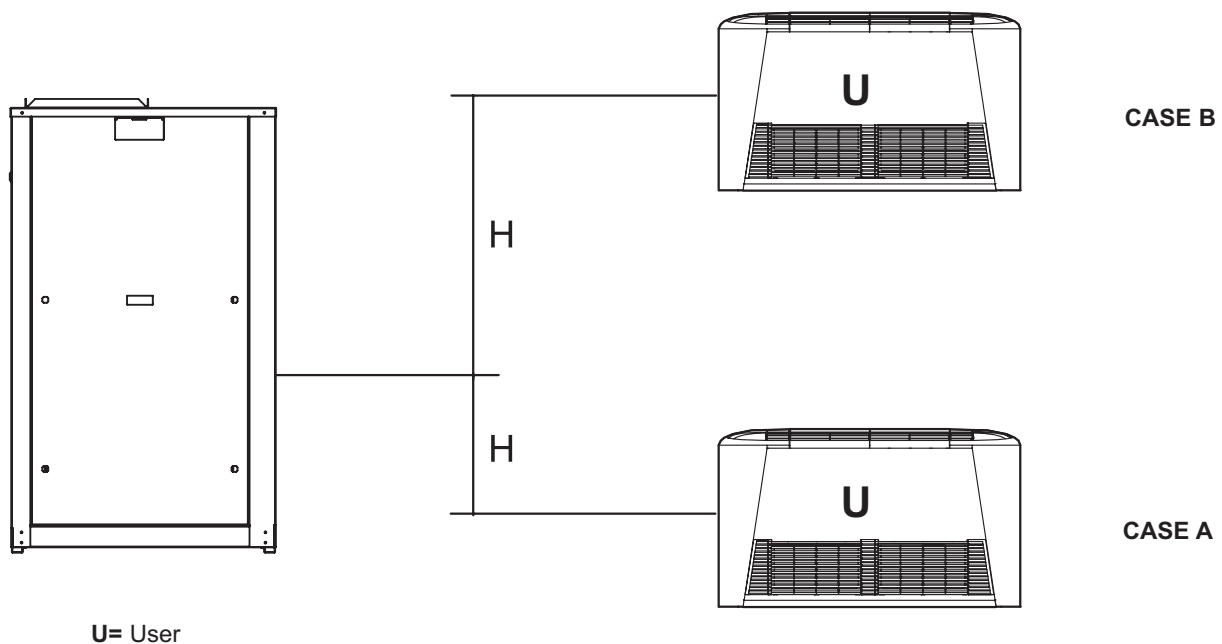

DIMENSIONAL DATA

Overall dimensions

Mod. 19 - 22 - 26 - 30

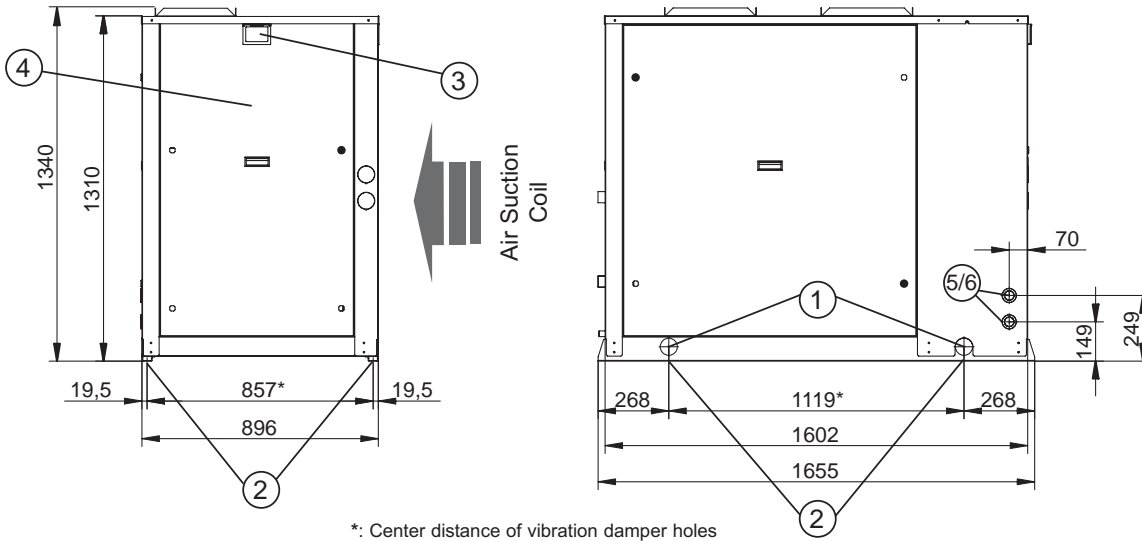

Mod.40 - 51

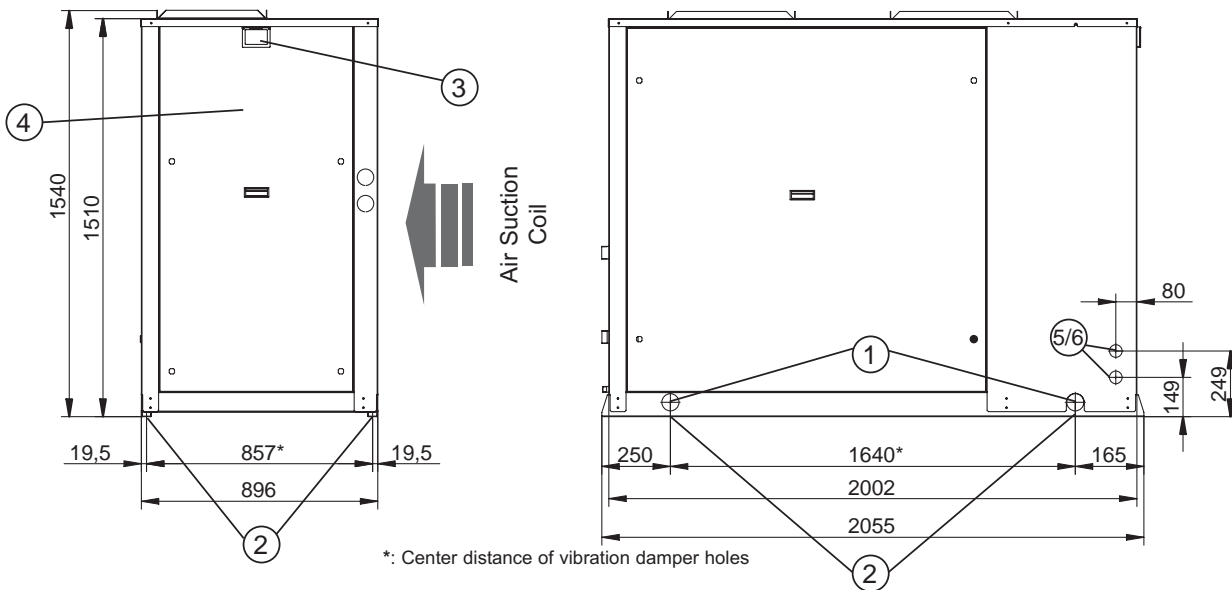

N.B.: Measurements given in mm.

Description of the components

- | | |
|----------------------------------------------------|------------------------------------------------------|
| 1 - Lifting holes - nr.4 - Ø65 mm | 4 - Compressor compartment access panel |
| 2 - Vibration-damping fixing holes - nr.4 - Ø13 mm | 5 - Electric power supply input hole - nr.1 - Ø36 mm |
| 3 - Electric control and monitoring panel | 6 - Accessory cable inlet hole - nr.1 - Ø36 mm |

Weight unit

To correctly install the unit, comply with the measurements for the free area that must be left around the machine, as shown in the drawing.

Standard Version unit weights

UNIT VERSION	COOLING MODE						HEATING MODE						UM
	19	22	26	30	40	51	19	22	26	30	40	51	
Transport weight	255	262	273	280	407	456	282	290	304	310	454	505	kg
Operating weight	256	264	275	282	410	460	283	292	306	312	457	509	kg

Standard Version unit weights with Storage and Pumping Module accessory (MAP)

Transport weight	315	322	333	340	482	531	342	350	364	370	529	580	kg
Operating weight	456	464	475	482	665	715	483	492	506	512	712	764	kg

DIMENSIONAL DATA

Position of wet connections

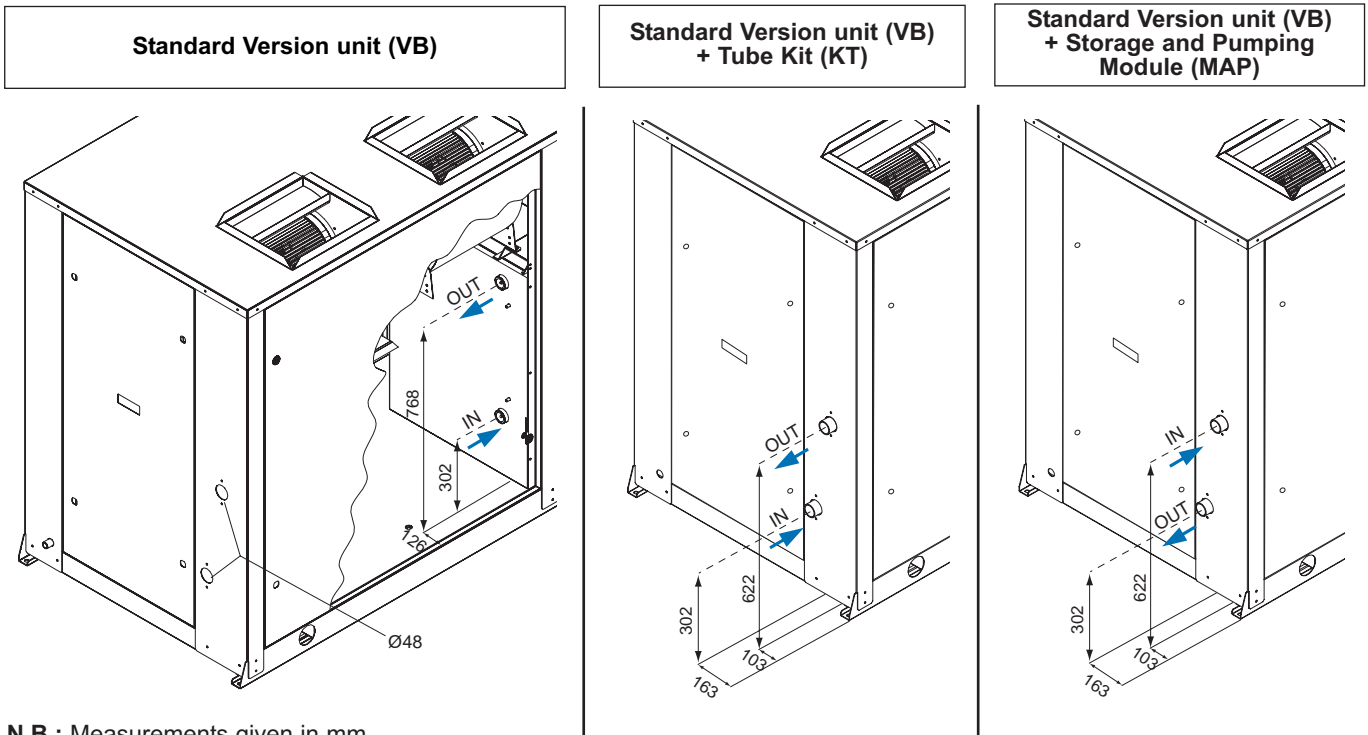

N.B.: Measurements given in mm.

Version	Standard Version unit (VB)		Standard Version unit (VB) + Tube Kit (KT)		Standard Version unit (VB) + Storage and Pumping Module (MAP)	
Mod.	19 ÷ 30	40 - 51	19 ÷ 30	40 - 51	19 ÷ 30	40 - 51
IN / OUT	1" 1/4 M	1" 1/4 M	1" 1/4 M	1" 1/2 M	1" 1/4 M	1" 1/2 M

Minimum space required for operation

Refer to the figure alongside for the dimensions of the unit.

To correctly install the unit, comply with the measurements for the free area that must be left around the machine, as shown in the figure.

The distances must be doubled if the unit is to be installed in a pit.

NOTE: Allow for a clear area of not less than 2.5 meters above unit.

The functional areas must be doubled if multiple units are installed.

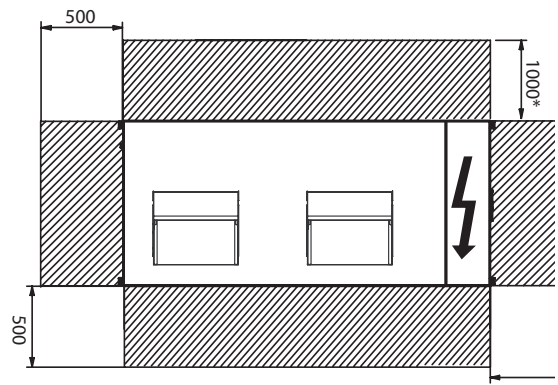

Mod.	19÷30	40-51
A	1100	1400

ferroli

COD. 3QE21640



Ferrol spa - 37047 San Bonifacio (Verona) Italy - Via Ritonda 78/A
tel. +39.045.6139411 - fax +39.045.6100933 - www.ferrol.it